

DISCUS

Event Safety

- Discus circles should be enclosed with a cage, and an extending fence to protect other areas on which events may be conducted should also be considered.
- The Chief Official should stand outside the cage alongside the ring in a safe position on the right-hand side of a right-handed thrower and vice-versa.
- Apart from the Chief Official and the Official on the sector line and/or spiking, everyone should stand behind the athlete, and at least 1m away from the safety cage and the landing sector should be clear. Where there is not a cage, officials and athletes must stand at least 2m behind the thrower except the Chief Official and the Official on the sector line and/or spiking and the landing sector should be clear.
- The discus should be CARRIED back to the circle - never thrown.

Officials Required

- **Two officials at throwing circle.** Tasks include watching for invalid throws, measuring, and pulling the end of the tape back through the centre of the circle.
- **Two officials at side of Sector.** Tasks include locating and marking the point of impact of the discus.
- **One official for recording, calling next athlete and timing.**

Equipment

- **Sector and Circle:** Clearly marked (as below)
- **Tape Measure:** (50-100 metres)
- **Discus:** (as specified below, provided by the Organising Body)
- **Spike:** To hold zero end of tape at the nearest edge of the mark made by the discus on landing
- **Recording Sheet:** For recording all performances
- **Cloth:** To wipe and clean the discus
- **Broom:** To sweep the surface of the discus circle.

Venue Dimensions

- The discus is thrown from a circle into a sector of 34.92°. The inside diameter of the circle is 2.50mts. All lines used to mark the circle and sector, are 50mm wide.

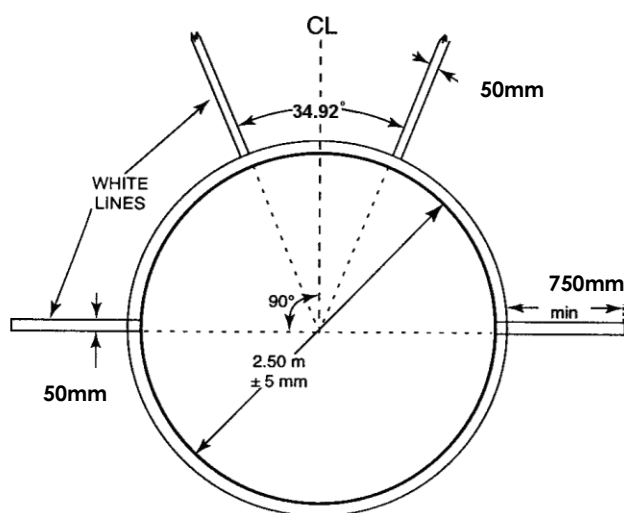

LAYOUT OF DISCUS CIRCLE

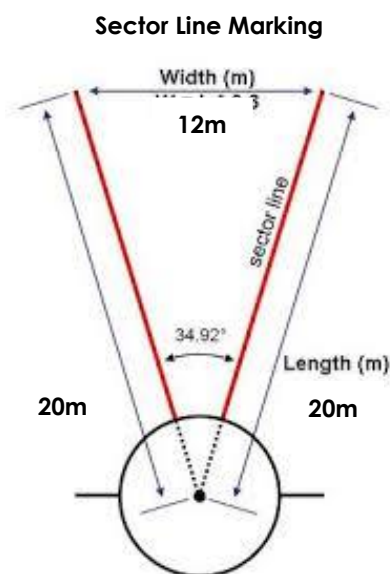

Implement Weights - Discus

U6 – U7	350g
U8 - U11	500g
U12 – U13	750g
U14 – U16, U17 Girls	1kg
U17 Boys	1.5kg

Number of Trials

- Each athlete is entitled to a maximum of 3 trials, differences may apply at Centres and Region / State events and some athletes may have 4 trials if a top 8 is conducted.
- Centres can schedule less trials, if programming restrictions such as twilights, or other constraints limit the available time to conduct the full program.

Valid Trial

- The trial must be commenced from a stationary position inside the circle. Note, stationary refers to both feet of the athlete, not arms or hands or other parts of the athlete's body.
- The athlete must not leave the circle until the discus has landed.
- The athlete must not touch the top of the circle or the ground outside the circle during the trial with any part of their body. They can touch the inside of the circle. Note: it will not be considered a failure if the touch happens during the rotation, back of the centre line.
- For a valid trial, the discus must fall so that the point of impact is within the inner edge of the lines marking the sectors.
- The athlete may enter the circle from any direction (preferably from the rear half of the circle) but must exit from the rear half of the circle.
- The athlete may during each trial, stop and place the discus down inside or outside the circle and then recommence the trial again, providing that no other infringement has occurred within the time limit.
- Once competition has begun, athletes will not be permitted to use the circle or ground within the sector for practice trials, with or without implements.
- If an athlete fails to commence an attempt within 60 seconds of their name being called by the Official in charge, a failure will be recorded.

Method of Measurement

- Officials select the imprint mark made by the discus on landing closest to the circle. The selected point is marked by the spike and the zero end of the tape is held at the spike.
- The tape is drawn tight through the centre of the circle.
- The distance is measured at the point where the tape crosses the inner edge of the circle.
- The distance is recorded to the nearest centimetre below the distance measured unless the reading is a whole centimetre.
- If the discus hits the cage and deflects back into the sector it will be a valid trial and measured providing no other infringement occurs.

Recording

- Best performances should be circled or highlighted.
- Ties are broken by referring to the next best throw.

Athlete	1st Trial	2nd Trial	3rd Trial	Best	Place
A	14.75	X	14.62	14.75	4
B	15.35	14.92	15.88	15.88	2
C	14.65	14.35	14.75	14.75	3
D	15.88	15.35	15.03	15.88	1
E	X	X	X	NM	NM

- D beats B on count back to **3rd** best throw – 15.03mt vs 14.92mt
- C beats A on count back to **2nd** best throw – 14.65mt vs 14.62mt

- X should be used to indicate a failure, "No Throw".
- NM is used to indicate no measurement.

SHOT PUT

Event Safety

- The Chief Official should stand alongside the ring in a safe position on the right-hand side of a right-handed thrower and vice versa.
- Apart from the Chief Official and the official on the sector line and/or spiking, everyone should stand 2m behind the athlete and the landing sector should be clear.
- The shot should be CARRIED back to the circle - never thrown.

Equipment

- **Sector and Circle:** Clearly marked (as below)
- **Tape Measure:** (20 metres)
- **Shot:** (as specified below, provided by the Organising Body)
- **Spike:** To hold zero end of tape at the nearest edge of the mark made by the shot on landing
- **Recording Sheet:** For recording all performances
- **Cloth:** To wipe and clean the shots.
- **Broom:** To sweep the surface of Shot Put circle

Officials Required

- **Two officials at putting circle:** Tasks include watching for invalid throws, measuring, and pulling the end of the tape back through the centre of the circle.
- **Two officials at side of Sector:** Tasks include locating and marking the point of impact of the shot and returning the shot to the circle.
- **One official for recording, calling next athlete and timing.**

Venue Dimensions

- The shot is 'put' from a circle into a Sector of 34.92°. The inside diameter of the circle is 2.135m. All lines used to mark the circle and sectors are 50mm wide.
- A stop/kick board measuring 1.22m Long, 100mm high and 114mm wide will be used.

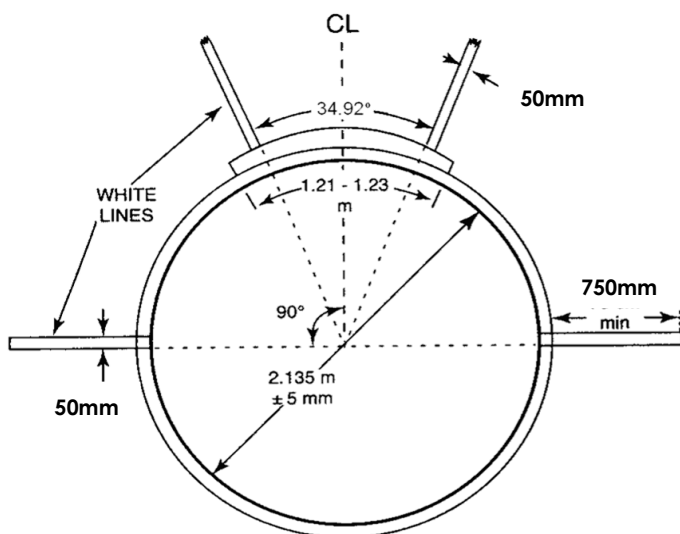

LAYOUT OF SHOT CIRCLE

