

- X should be used to indicate a failure, "No Throw".
- NM is used to indicate no measurement.

SHOT PUT

Event Safety

- The Chief Official should stand alongside the ring in a safe position on the right-hand side of a right-handed thrower and vice versa.
- Apart from the Chief Official and the official on the sector line and/or spiking, everyone should stand 2m behind the athlete and the landing sector should be clear.
- The shot should be CARRIED back to the circle - never thrown.

Equipment

- **Sector and Circle:** Clearly marked (as below)
- **Tape Measure:** (20 metres)
- **Shot:** (as specified below, provided by the Organising Body)
- **Spike:** To hold zero end of tape at the nearest edge of the mark made by the shot on landing
- **Recording Sheet:** For recording all performances
- **Cloth:** To wipe and clean the shots.
- **Broom:** To sweep the surface of Shot Put circle

Officials Required

- **Two officials at putting circle:** Tasks include watching for invalid throws, measuring, and pulling the end of the tape back through the centre of the circle.
- **Two officials at side of Sector:** Tasks include locating and marking the point of impact of the shot and returning the shot to the circle.
- **One official for recording, calling next athlete and timing.**

Venue Dimensions

- The shot is 'put' from a circle into a Sector of 34.92°. The inside diameter of the circle is 2.135m. All lines used to mark the circle and sectors are 50mm wide.
- A stop/kick board measuring 1.22m Long, 100mm high and 114mm wide will be used.

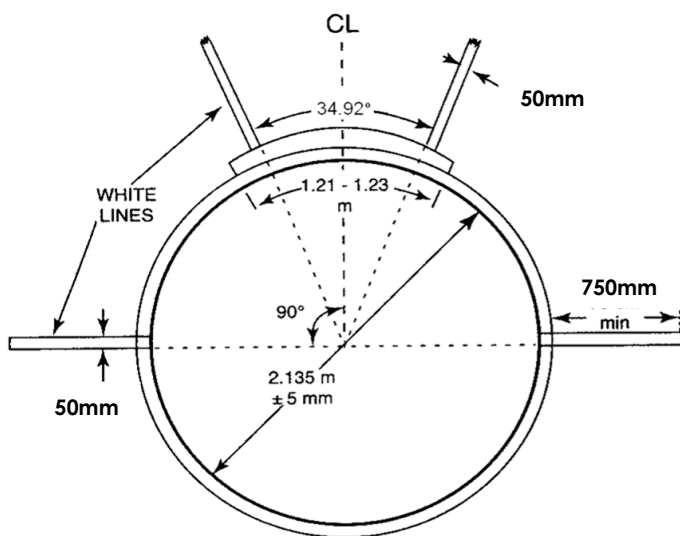

LAYOUT OF SHOT CIRCLE

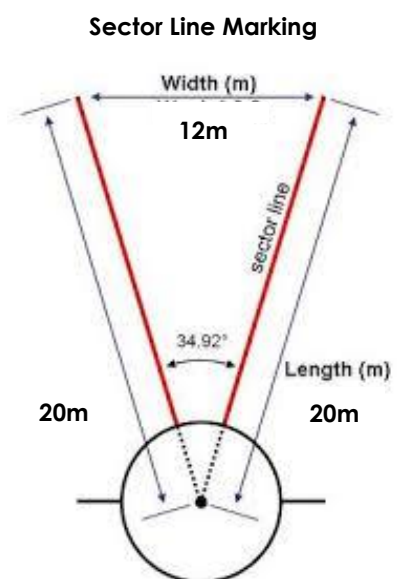

Implement Weights – Shot Put

U6 - U7	1kg
U8	1.5kg
U9 – U12	2kg
U13G - U17G	3kg
U13B - U14B	3kg
U15B - U16B	4kg
U17B	5kg

Number of Trials

- Each athlete is entitled to a maximum of 3 trials, differences may apply at Centres and Region / State events and some athletes may have 4 trials if a top 8 is conducted.
- Centres can schedule less trials, if programming restrictions such as twilights, or other constraints limit the available time to conduct the full program.

Valid Trial

- The trial must be commenced from a stationary position inside the circle. Note, stationary refers to both feet of the athlete, not arms or hands or other parts of the athlete's body
- The athlete must not leave the circle until the shot has landed.
- The athlete must not touch the top of the circle or stop/kick board, or the ground outside the circle during the trial with any part of their body. They can touch the inside of the stop/kick board. Note: it will not be considered a failure if the touch happens during the rotation, back of the centre line.
- The shot must land where the 'impact mark' is within the inner edges of the lines marking the sector.
- The athlete may enter the circle from any direction (preferably from the rear half of the circle) but must exit from the rear half of the circle.
- The shot must be put from the shoulder with one hand only. At the start of the trial the shot should touch or be in close proximity to the neck or chin and should not be dropped below this position during the action of putting.
- The shot shall not be taken behind the line of the shoulders.
- The athlete may during each trial, stop and place the shot down inside or outside the circle and then recommence the trial again, providing that no other infringement has occurred within the time limits.
- Once competition has begun, athletes will not be permitted to use the circle or ground within the sector for practice trails with or without implements.
- If an athlete fails to commence an attempt within 60 seconds of their name being called by the Official in charge, a failure will be recorded.

Method of Measurement

- Officials select the 'impact mark' made by the shot on landing closest to the circle. The selected point is marked by the spike and the zero end of the tape is held at the spike.
- The tape is drawn tight through the centre of the circle.
- The distance is measured at the point where the tape crosses the inner edge of the stop board.
- The distance is recorded to the nearest centimetre below the distance measured unless the reading is a whole centimetre.

Recording

- Best performances should be circled or highlighted.
- Ties are broken by referring to the next best throw.

Athlete	1st Trial	2nd Trial	3rd Trial	Best	Place
A	4.76	X	4.62	4.76	4
B	5.35	4.92	5.88	5.88	2
C	4.65	4.35	4.76	4.76	3
D	5.88	5.35	5.03	5.88	1
E	X	X	X	NM	NM

- D beats B on count back to **3rd** best put – 5.03mt vs 4.92mt
- C beats A on count back to **2nd** best put – 4.65mt vs 4.62mt
- X should be used to indicate a failure / invalid trial
- Results will always show "NM when an athlete fails to record a measurable trial.

JAVELIN

Warning: Javelins are dangerous implements.

The javelin is a form of spear and as such is a lethal weapon; it can be deflected by gusts of wind.

Event Safety

- The Chief Official should stand alongside the runway in a safe position on the right-hand side of a right-handed thrower and vice-versa.
- Apart from the Official on the Sector Line, everyone should stand behind the athlete and the landing Sector should be clear.
- The Javelin should be CARRIED back to the runway in a vertical position, tip down, never thrown. Never run back with the Javelin, always walk as the grass can be slippery.

Equipment

- **Runway:** Clearly marked (as below)
- **Tape Measure:** (50-100 metres)
- **Javelins:** (As specified below and provided by Organising Body)
- **Spike:** To hold zero end of tape where the metal head of the Javelin, first struck the ground
- **Recording Sheet:** For recording all performance
- **Cloth:** To wipe and clean the Javelins
- **Broom:** To sweep the Javelin runway
- **Marker:** For athletes to mark the start point of their run-up

Officials Required

- **Two officials at throwing arc.** Tasks include watching for invalid throws, measuring, and pulling the end of the tape back through the centre of the circle of which the arc is a part (8mts from the arc).
- **Two officials at side of the Sector.** Tasks include finding and marking the point of impact of the metal head of the Javelin and returning them.
- **One official for recording, calling next athlete and timing.**

Venue Dimensions

- The length of the runway may include the length of the track (8 lanes) and the width is 4mts with the lines 50mm wide. The "arc" line should be 70mm in width. Markers can only be used at the side of runway.